

## Technical Data Sheet

# PercoTop<sup>®</sup> EP HS Protective Coating Material CS591

### 2K HS EP Primer

#### Description

High-build surface-tolerant 2K anti-corrosive paint based on epoxy resins.

#### Products

CS591	EP HS Protective Coating Material
CS572	Activator EP HS Coating Material
CS561	Thinner EP Coating Material

#### Colours

? approx. RAL 7001 silver grey

#### Properties

- ? Excellent resistance against humidity, weather and mechanical load.
- ? Perfect corrosion protection for manually derusted surfaces (St3 according to DIN EN ISO 12944-4)

#### Substrates

? Steel

## Technical Data Sheet

# PercoTop<sup>®</sup> EP HS Protective Coating Material CS591

## 2K HS EP Primer



### Surface preparation

- ? The surface must be free from corrosion, rolling skin, oil, salt, humidity and any other contamination. Surface pretreatment at least as per St2. Loose old paint coat should be tested on bearing strength.
- ? Because of the wide variety of substrates and their manufacturing processes, a preliminary test should be carried out on the respective substrate to ensure that the pretreatment is sufficient to guarantee a perfect adhesion. For information on substrate and respective surface preparation, refer to the supplier's specifications.

### VOC value ready for use (EU Directive 1999/13/EC)

- ? 275g/l Mixture as per TDS ( RFU )

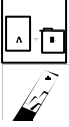
## Product preparation







 <b>Mixing ratio</b>	CS591 CS572	<b>Volume</b>	<b>Weight</b>
		16 4	100 17
<b>Thinner</b>	CS561		
 <b>Pot life at 20°C</b>	4 hours		
<b>Recommended dry film thickness</b>	Dry 125m $\mu$ , wet 167m $\mu$ or dry 250m $\mu$ , wet 335m $\mu$		

## Technical Data Sheet

# PercoTop<sup>®</sup> EP HS Protective Coating Material CS591

2K HS EP Primer

### APPLICATION:

	Application viscosity DIN 4 at 20°C (s)	Thinner nung (%)	Spritz- düse (mm)	Druck (bar)	Anzahl der Spritz- gänge
 Gravity feed  Suction feed (High pressure spraying)	According to the advice of the DuPont Technical Representative.				
 HVLP (Low pressure spraying)	According to the advice of the DuPont Technical Representative.				
 Airless Airmix	mixing viscosity	0-5%	0,019"-0,023"	2,0 – 3,5 Atomizing pressure:  ca. 80-120 Material pressure	2-4
 Pressure pot Membrane pump (High pressure spraying)	According to the advice of the DuPont Technical Representative.				
 Electrostatic	According to the advice of the DuPont Technical Representative.				

## Technical Data Sheet

# PercoTop<sup>®</sup> EP HS Protective Coating Material CS591

2K HS EP Primer

### Drying

<b>Air drying Temperature:</b>	+5°C	+10°C	+20°C	+30°C
<b>Dust dry</b>	16hours	10hours.	6hours.	4hours.
<b>Dry to recoat</b>	24hours	16hours	12hours.	10hours.
<b>Dry</b>	minimum 24 hours / maximum 14 days			

### Recoatability

<b>Recoatable</b>	PercoTop <sup>®</sup>
<b>Remarks</b>	

### Product Data

<b>Package viscosity</b>	> 100s ISO 2431-1993 6mm
<b>Flash point</b>	+25°C



	<b>Solids</b> Weight (%)	<b>Solids</b> Volume (%)	<b>Density:</b> (kg/l)	<b>Theoretical Coverage:</b> (at 125 m $\mu$ ) (m <sup>2</sup> /kg)	<b>Theoretical material consumption</b> (at 40 m $\mu$ ) (g/m <sup>2</sup> )
As supplied		75%	approx.1,42g/cm <sup>3</sup>	4,2m <sup>2</sup> /kg	

## Technical Data Sheet

# PercoTop<sup>®</sup> EP HS Protective Coating Material CS591

2K HS EP Primer

### Remarks

	? Stir before use.
	? Before application a color comparison is recommended. ? During application object temperature must reach at least 3°C above dew point.
<b>Shelf life at 5°C to 35°C</b>	? Refer to the label on the original can.

### Safety

- ? Consult the Safety Data Sheet prior to use.
- ? Observe the precautionary notices displayed on the container.

### Information

The information provided herein corresponds to our knowledge on the subject at the date of its publication. This information may be subject to revision as new knowledge and experience becomes available. The data provided fall within the normal range of product properties and relate only to the specific material designated; these data may not be valid for such material used in combination with any other materials or additives or in any process, unless expressly indicated otherwise. The data provided should not be used to establish specification limits or used alone as the basis of design; they are not intended to substitute for any testing you may need to conduct to determine for yourself the suitability of a specific material for your particular purposes. Since DuPont cannot anticipate all variations in actual end-use conditions DuPont makes no warranties and assumes no liability in connection with any use of this information. Nothing in this publication is to be considered as a license to operate under or a recommendation to infringe any patent rights.

Copyright© 2009 DuPont. All rights reserved. The DuPont Oval Logo, DuPont<sup>™</sup>, The miracles of science<sup>™</sup> and all products denoted with <sup>®</sup> or <sup>™</sup> are registered trademarks or trademarks of E. I. du Pont de Nemours and Company or its affiliates.